

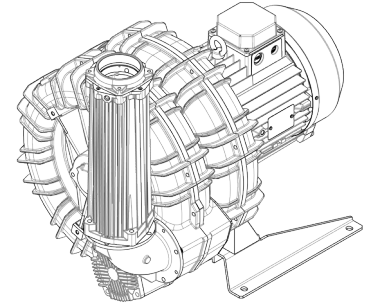

Technical Characteristics	
-	Aluminum alloy construction
-	Smooth operation
-	Maintenance free
Electric Motor	
-	IE3 Wide Range cURus Motors
-	IP 55 protection rating, class F insulation, suitable for operating with inverter (refer to FPZ)
-	Thermal Protector (PTO) as standard
Options	
-	Special voltages (IEC 60038)
-	Surface treatments
-	Increased seal version

~3	[V] (Y / Δ)	[Hz]
IE3	690 / 400	50
	795 / 460	60
Wide Range	600 – 720 / 345 – 415	50
	660 – 830 / 380 – 480	60

Supply voltage - [Tolerance on the fixed voltage value ± 10%, in range ± 5%.]



Performance Table

P _n [kW]	Frequency [Hz]	Δp _{max} [mbar]		Q _{max} [m ³ /h]	Leq ¹ [dB(A)]	Weight [kg]	H ² [mm]	Current Consumption (Y/Δ) [A]		Cosφ [-]	Speed [rpm]
		Suction	Compression					IE3	Range		
7.5	50	375	325	518	77	100.5	580	8.95 / 15.5	9.06-9.30 / 15.7-16.1	0.78	2940
9	60	325	290	625	79	100.5	580	8.78 / 15.2	9.71-8.97 / 16.8-15.5	0.82	3535
9.2	50	425	425	518	77	105.5	620	10.3 / 17.8	10.9-10.5 / 18.9-18.1	0.83	2935
11	60	425	390	625	79	112	620	10.2 / 17.7	11.7-10.3 / 20.3-17.8	0.86	3530
11	50	-	550	518	77	112	620	12.5 / 21.6	13.0-12.8 / 22.6-22.2	0.81	2940
13	60	-	490	625	79	112	620	12.3 / 21.2	13.8-12.4 / 23.9-21.5	0.84	3535
15	50	-	625	518	77	129	695	16.2 / 28.1	17.5-16.4 / 30.4-28.4	0.84	2935
17	60	-	625	625	79	129	695	15.5 / 26.8	17.8-15.5 / 30.9-26.9	0.86	3535

1. Noise level measured at a distance of 1 m with ducted intake and delivery, in accordance with Standard ISO 3744.
2. See figure "dimensions" at following page.

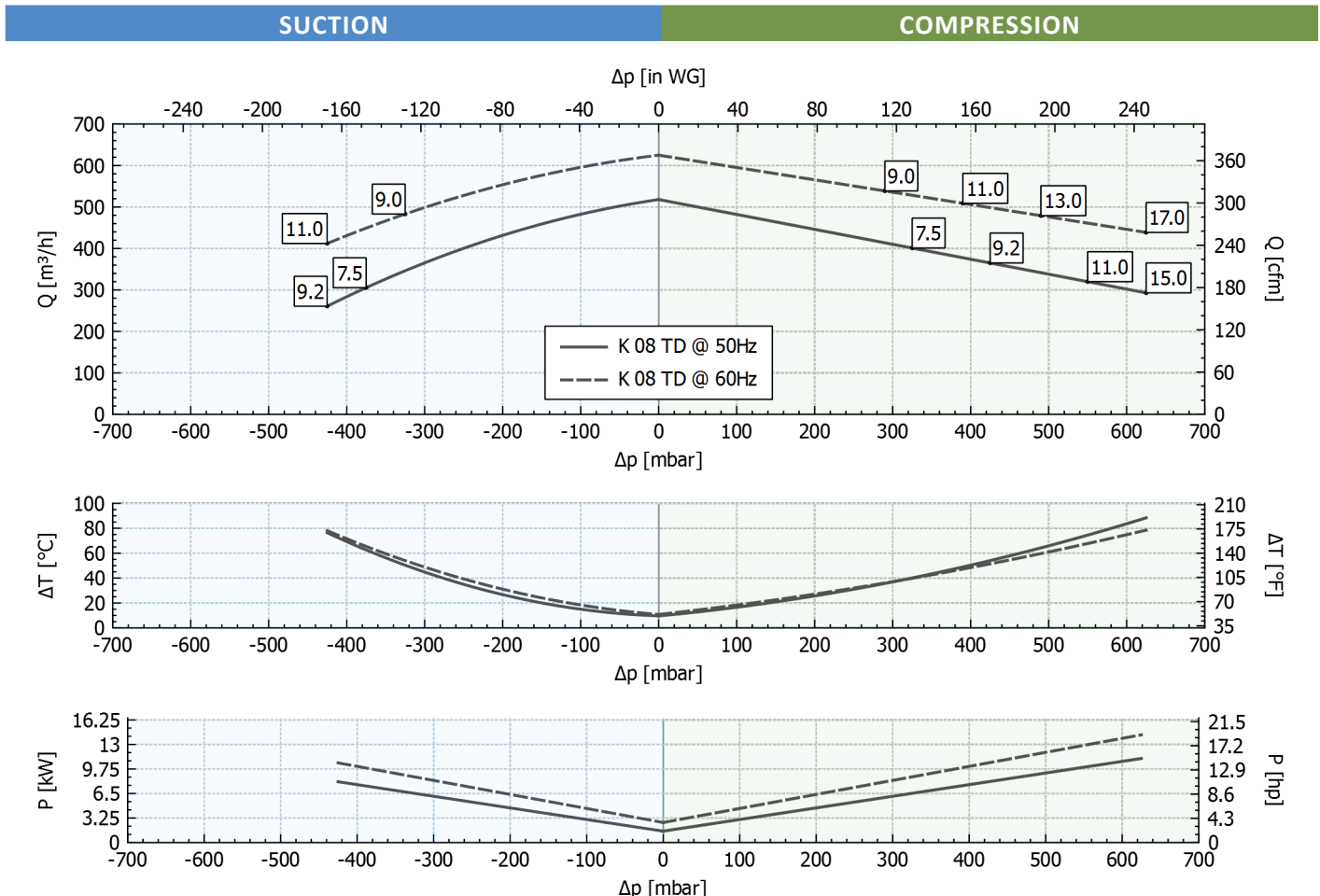

Tolerance on indicated values ± 10%.
Data subject to change without notice.
Curves referring to air at a temperature of 20 °C and atmospheric pressure of 1013 mbar (abs).

Dimensions

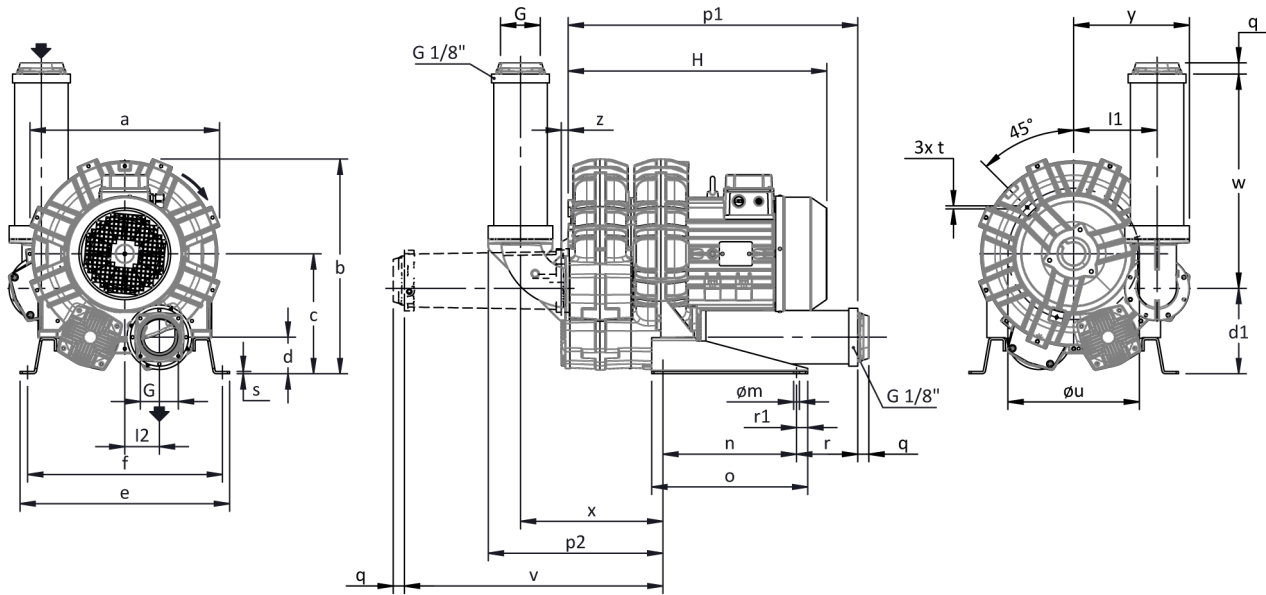

For all assembly options refer to FPZ.
Dimensions in mm
NOT Binding

a	b	c	d	d1	e	f	G	l	l1	l2	m	n	o	p1	p2	q	r	r1	s	t	u	v	w	x	y	z
457	498	269	82	192	480	448	G 3"	-	187	77.5	13	300	350	650	392	25	137	25	5	M8	310	581	481	319	260	16

INSTALLATION

- For proper operation of the machine, it must be provided with a suction FILTER and a vacuum/pressure limiting VALVE.
- Other accessories are available on request.
- Permissible ambient and fluid temperature in suction from -15 °C to +40 °C.
- Read the instruction manual carefully before installing the machine.